

## DATENBLATT / FACT SHEET



ART.-NR:	FARBTEMPERATUR:
010-128	2700K
009-493	3000K
010-612	4000K

**SQUEEZE 4**

## PENDELLEUCHE / SUSPENDED LUMINAIRE

LED.next höhenstellbare Pendelleuchte für den Home- und Loungebereich. Einzel oder aber auch in Gruppen anwendbar. Lichtaustritt 100 % direktstrahlend, breit abstrahlend, durch Softlight Diffusor. Pink hochglänzend. Ausführung mit integriertem Konverter in Baldachingehäuse zum Anschluss an 230-V-Auslass mit zusätzlicher Gestendimmung auf der Leuchte. Edelstahlseilabhängung, einstellbar von 300–2000 mm. Design: Karim Rashid

32 W LEDnext ≈ 200 W Halogen

Height adjustable LED.next suspended luminaire for use in the home and lounge areas. Can be used individually or in groups. 100 % direct beam, wide beam, through Softlight Diffuser. Brilliant pink. Version with integrated converter in canopy housing for connection to 230 V outlet with additional gesture dimming on the luminaire itself. Stainless steel suspension cables, adjustable from 300–2000 mm. Design: Karim Rashid

32 W LEDnext ≈ 200 W halogen

## TECHNISCHE DATEN / TECHNICAL FACTS

**Artikel:**

SQUEEZE 4

**Art.-Nr.: Farbtemperatur:**

010-128 2700 K

009-493 3000 K

010-612 4000 K

**Beschreibung/ Ausführung:**

Pendelleuchte

**Hersteller:**

Nimbus Group GmbH

Sieglesstr. 41, D-70469 Stuttgart

Tel.: +49(0)711 / 63 30 14 - 0

Fax: +49(0)711 / 63 30 14 - 14

info@nimbus-group.com

www.nimbus-group.com

**Abmessungen:**

500 x 500 x 2000 mm

**Material:**

Gehäuse: PMMA pink hochglänzend

Wandblech: Stahl

**Gewicht:**

3200 Gramm

**Lichttechnik:****LED.next** -Technologie integriert**Anschluss-Leistung:**

32 W / 230 Volt AC

**Anzahl LED´s:**

144 Stück

**Schutzart:**

IP 20

**Lichtstrom:**

1565 lm

**Abstrahlcharakteristik:**

breit abstrahlend

**Lichtverteilung:**

100 % direktstrahlend

**RA:**

80

**Prüfzeichen:****Reinigungs- und Pflegehinweise:**

Leuchte beim Reinigen vom Netz trennen. Keine ätzenden oder abrasiven Reinigungsmittel verwenden. Wir empfehlen, die Leuchte nur mit einem Microfasertuch o. ä. trocken zu reinigen.

**product:**

SQUEEZE 4

**product-nr.: colour temperature:**

010-128 2700 K

009-493 3000 K

010-612 4000 K

**description/design:**

suspended luminaire

**manufacturer:**

Nimbus Group GmbH

Sieglesstr. 41, D-70469 Stuttgart

Tel.: +49(0)711 / 63 30 14 - 0

Fax: +49(0)711 / 63 30 14 - 14

info@nimbus-group.com

www.nimbus-group.com

**dimensions:**

500 x 500 x 2000 mm

**materials:**

housing: PMMA brilliant pink

mounting plate: steel

**weight:**

3200 gram

**light technology:****LED.next** -technology integrated**power supply:**

32 W / 230 Volt AC

**number of LED´s:**

144 Stück

**degree of protection:**

IP 20

**luminous flux:**

1565 lm

**directional characteristics:**

wide beam

**light distribution:**

100 % direct beam

**CRI:**

80

**certificates:****cleaning and care:**

switch of luminaire while cleaning. Do not use any acidly or abrasive cleanser. We recommend to clean the luminaire only with a microfibre towel.

# LICHTVERTEILUNGSKURVE UND ABSTRAHLCHARAKTERISTIK / LIGHT DISTRIBUTION CURVE AND DIRECTIONAL CHARACTERISTIC

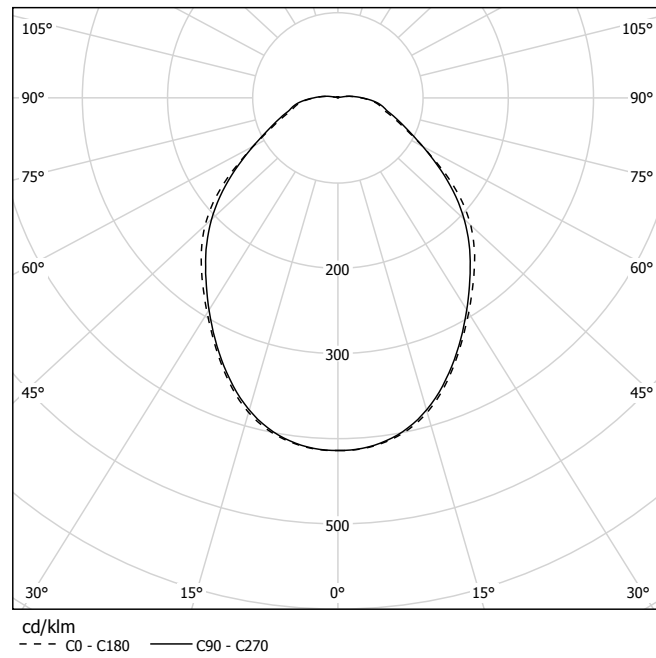

Lichtberechnungsdaten (EULUMDAT) unter [www.nimbus-group.com](http://www.nimbus-group.com)

## ISOMETRIE UND MASSE / SIZES

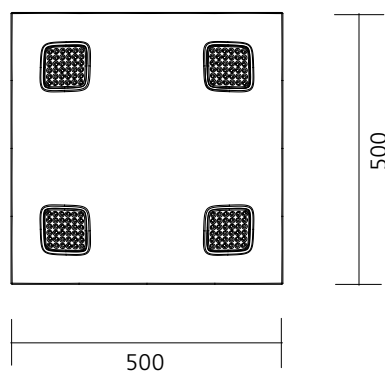
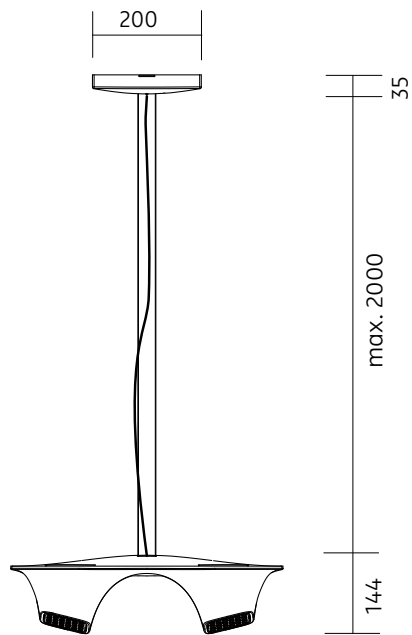
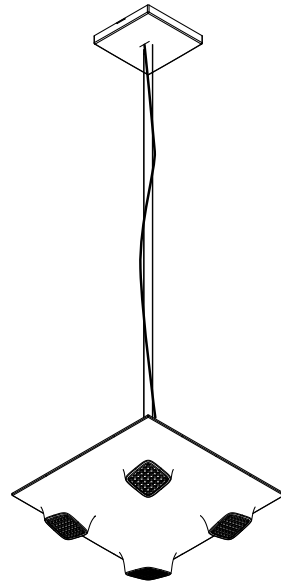

**SQUEEZE 4 LED.next**  
 PENDELLEUCHE / SUSPENDED LUMINAIRE

**nimbus<sup>x</sup>**

009-493 . 010-128 . 010-612

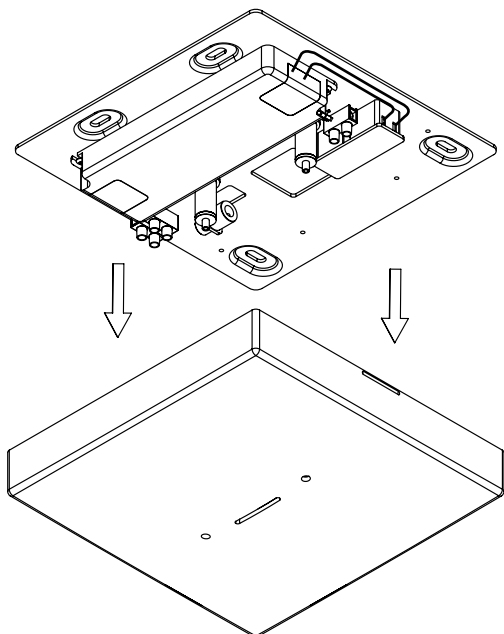

1

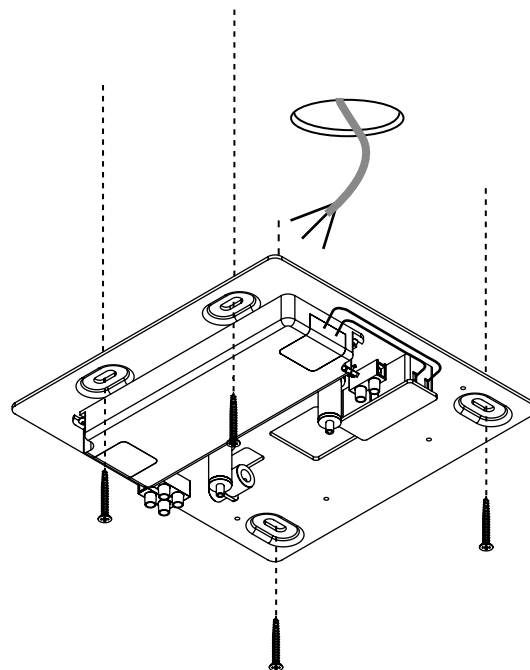

2



Leuchten dürfen nicht auf feuchtem oder leitendem Untergrund installiert werden.  
 Luminars may not be installed on a wet or conductive surface.

Anschluss an 230V AC  
 connection to 230V AC

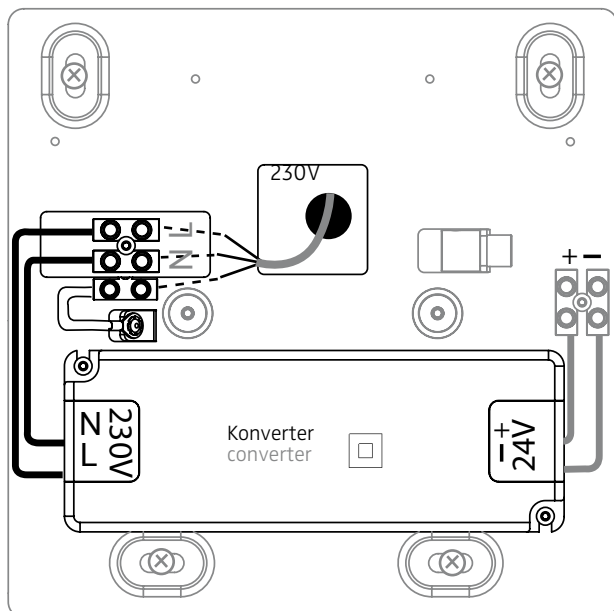

3

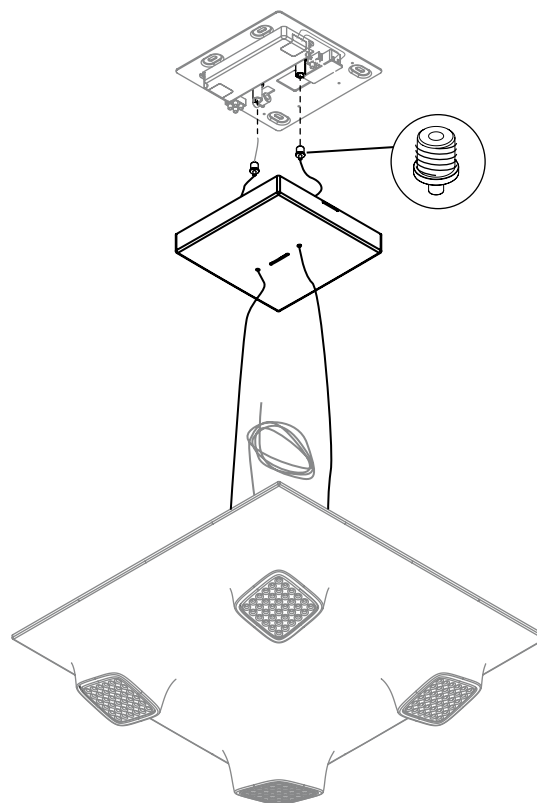

4



Der elektrische Anschluß darf nur vom Fachmann ausgeführt werden!  
 Must only be installed by a qualified electrician!

Anschluss an 24V DC  
connection to 24V DC

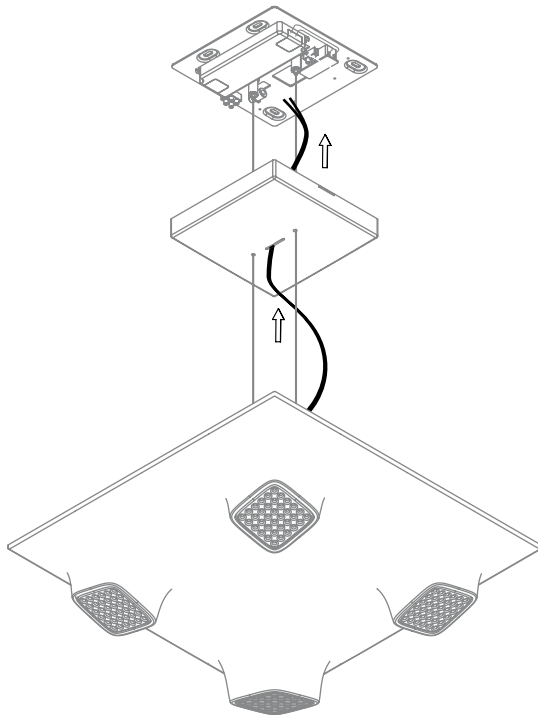

5

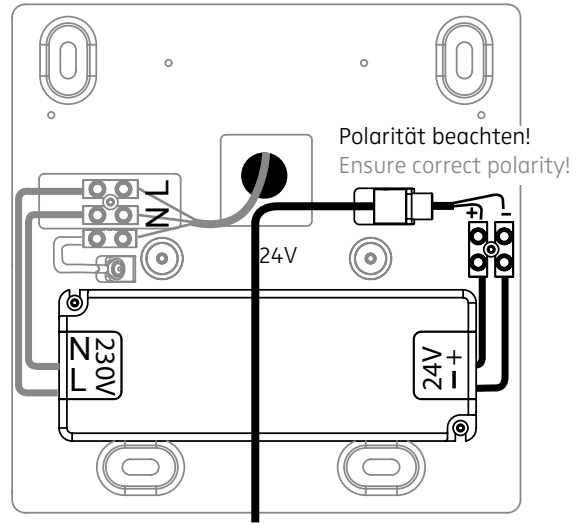

6

Kabel durch Zugentlastung sichern!  
Use strain relief clamps to protect cables!

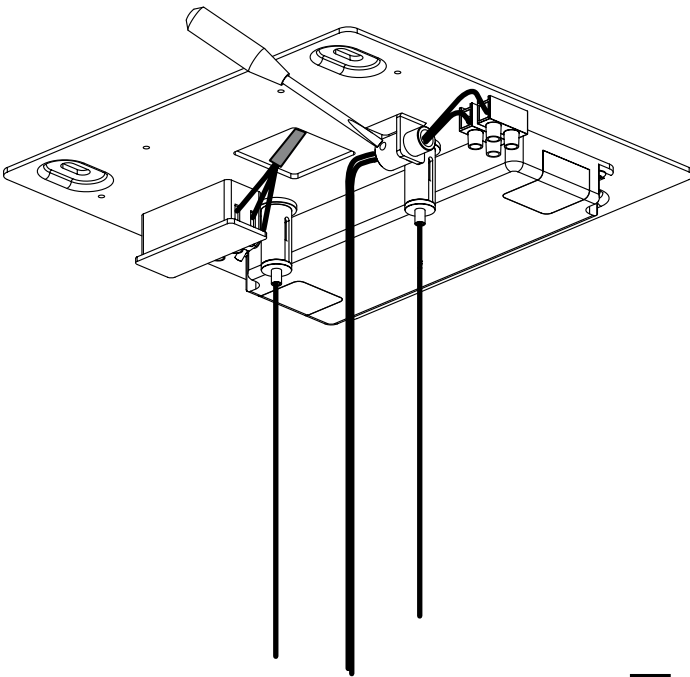

7

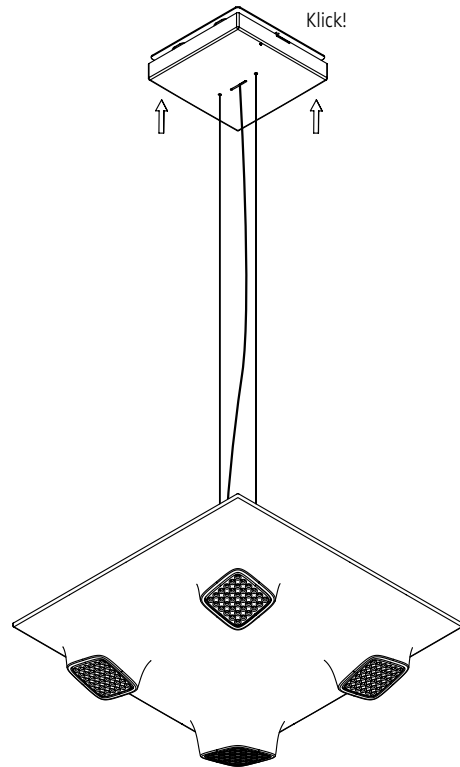

8

009-493 . 010-128 . 010-612

230V AC ~

230V AC ~

Bestückung

LEDnext 32 W

lamp type

LEDnext 32 W

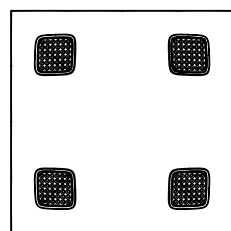

500

500

200

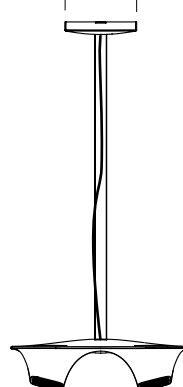

35

max. 2000

144



Schutzart IP 20  
protection degree IP 20



Leuchten dürfen nicht auf feuchtem  
oder leitendem Untergrund installiert  
werden.

Luminars may not be installed on a  
wet or conductive surface.

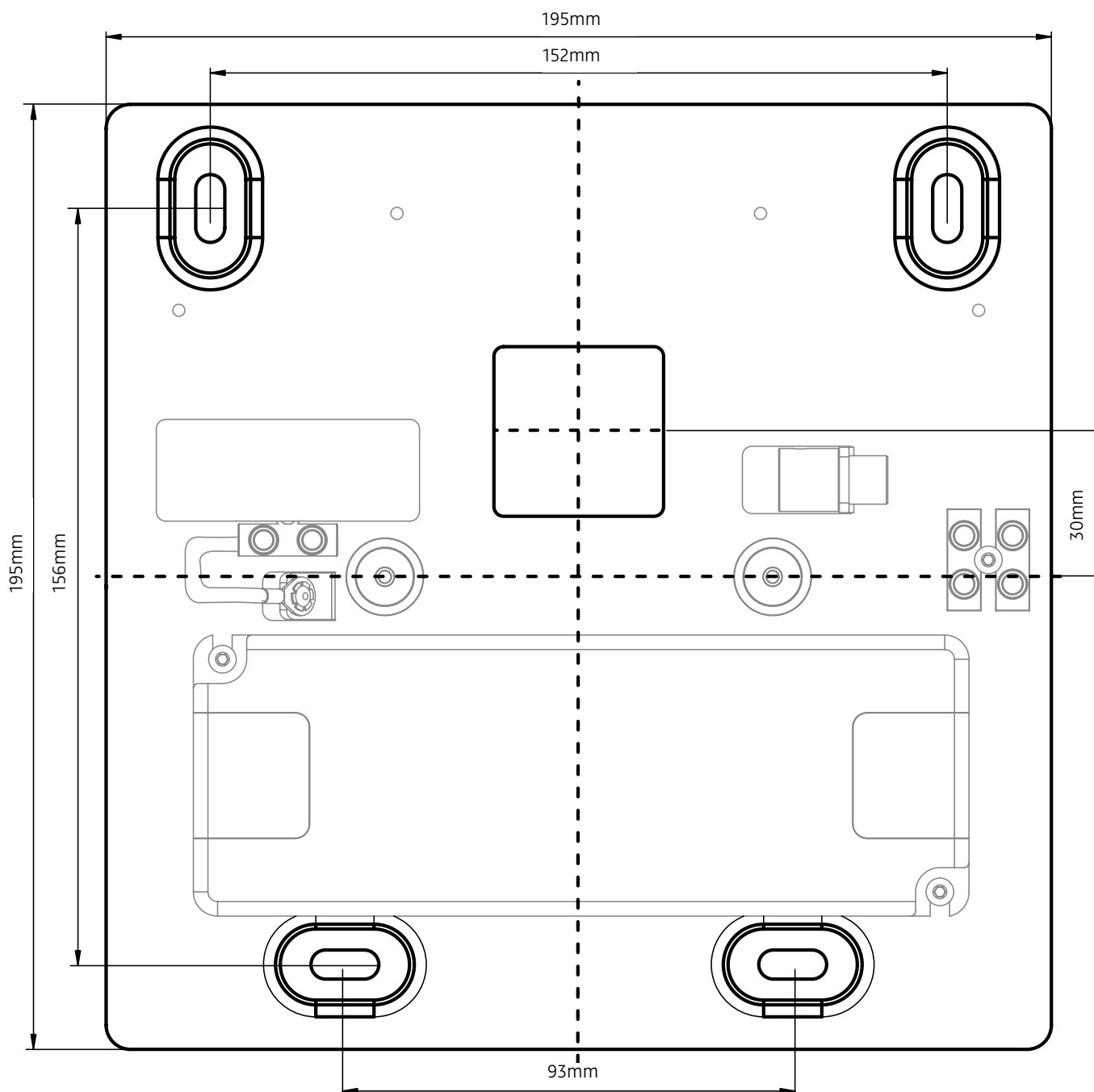

**MONTAGEBLECH/ MOUNTING PLATE**